

Spinnaker pole kit, dip pole

Assembly instructions

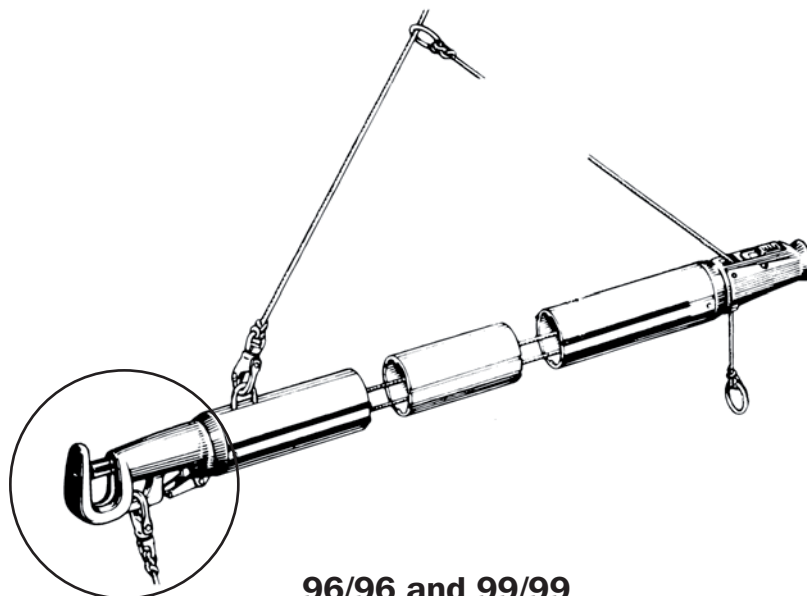

96/96 and 99/99



72/72 and 84/84

Required tools:

Hacksaw	Screwdriver for slotted head
Hammer	Pencil
Mandrel (max. diam. ø3,5mm)	Centre punch
Drill	Torch
Drillbit ø6,5mm	Tape
Rivet gun	Measuring tape
File	

1. Spinnaker pole kit - dip pole, section 72/72 and 84/84.

Fig. 1

- 1.1 The kit is supplied with the outboard end attached and the inboard end loose. The release line is attached to / fed through the inboard end to demonstrate how they finally should be arranged. Start by removing the inboard end fitting and any adaptor from the extrusion.
- 1.2 Calculate the XL dimension using the table below:

Section	Calculation of extrusion length
72/72	$L - (90 + 155) = \text{extrusion length XL}$
84/84	$L - (110 + 155) = \text{extrusion length XL}$

- 1.3 Mark the calculated length on the extrusion. It is easy to mark a straight and square cut if you draw along a paper folded around the extrusion, fig. 2.
- 1.4 Cut the extrusion with the hacksaw. Chamfer the edges with the file. Be careful not to damage the line and cord during the cutting operation.
- 1.5 Re-attach the releaseline to the inboard end fitting.

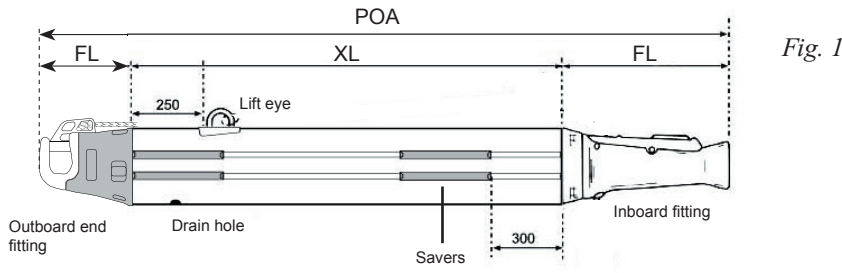
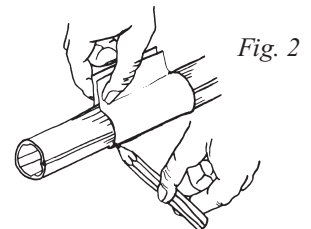

Fig. 2

- 1.6 Refit the inboard end fitting with adaptor (if any) and carefully check that it is correctly positioned in relation to the outboard one. (fig. 1).
- 1.7 Fit the enclosed lift eye using the supplied rivets. A self adhesive insulating sheet is fitted under the eye base. The holes in the extrusion are pre-drilled. Remove the rivet mandrels using the 3.5mm mandrel.
- 1.8 Mark the location of the holes for the inboard end fitting, according to PS736.
- 1.9 Check that the inboard end fitting with its adapter (if any) are firmly held against the extrusion. Drill the $\varnothing 4,9$ mm rivet holes and fix the fitting temporarily with a rivet for each hole drilled, **without** "pulling" them.
- 1.10 Remove the fitting and adapter (if any), then clean out any metal debris.
- 1.11 Attach the fitting using the supplied rivets. After "pulling" the rivets, remove the mandrels from the rivet bodies using the 3.5mm mandrel. Lift the inboard end of the pole and remove the mandrels through the drain hole at the outboard end.
- 1.12 Stretch the release line. Position the red ball approx. 200 mm outside the fitting and lock it with a stopping knot. Bury the knot in the cavity of the ball. Cut off the spare rope and melt the end.
- 1.13 Slide the inboard savers into position as shown in fig. 1 and lock them by deforming the groove at the ends of the savers using a screwdriver. Note how the outboard savers are locked, see fig. 4.



Fig. 4

2. Spinnaker pole kit - dip pole, section 96/96 and 99/99.

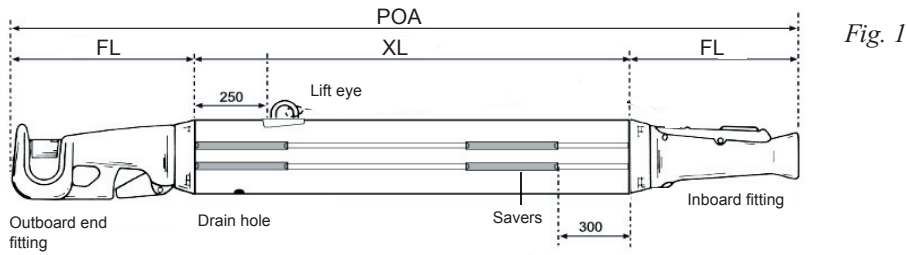

- 2.1 The kit is supplied with the outboard end attached and the inboard end loose. The release line is attached to / fed through the inboard end to demonstrate how they finally should be arranged. Start by removing the inboard end fitting and any adaptor from the extrusion.
- 2.2 Calculate the XL dimension using the table below:

Section	Calculation of extrusion length
96/96	$L - (215 + 195) = \text{extrusion length XL}$
99/99	$L - (215 + 195) = \text{extrusion length XL}$

- 2.3 Mark the calculated length on the extrusion. It is easy to mark a straight and square cut if you draw along the enclosed drilling jig folded around the extrusion, fig. 2.
- 2.4 Cut the extrusion with the hacksaw. Chamfer the edges with the file. Be careful not to damage the line and cord during the cutting operation.
- 2.5 Note the way the release line and the messenger for the lift retriever retraction cord pass through the loose inboard end. Pull out the line. Remove the cut part of the extrusion.
- 2.6 Re-attach the line and rubber cord to the fitting.
- 2.7 Refit the inboard end fitting with adaptor (if any) and carefully check that it is correctly positioned in relation to the outboard one. (fig. 1). Check that the line and rubber cord have not jammed
- 2.8 Fit the enclosed lift eye using the supplied rivets. A self adhesive insulating sheet is fitted under the eye base. The holes in the extrusion are pre-drilled. Remove the rivet mandrels using the 3.5mm mandrel.
- 2.9 Mark the location of the holes for the inboard end fitting, according to Ps736, supplied.

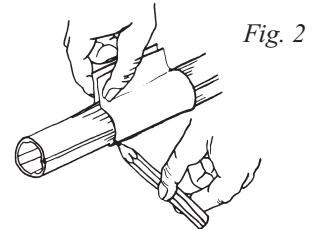

- 2.10 Check that the inboard end fitting with its adapter (if any) are firmly held against the extrusion. Drill the \varnothing 6,5mm rivet holes and fix the fitting temporarily with a rivet for each hole drilled, **without** "pulling" them.
- 2.11 Remove the fitting and adapter (if any), then clean out any metal debris.
- 2.12 Check using the torch that the line and cord have not twisted.
- 2.13 Attach the fitting using the supplied rivets. After "pulling" the rivets, remove the mandrels from the rivet bodies using the 3.5mm mandrel. Lift the inboard end of the pole and remove the mandrels through the drain hole at the outboard end.
- 2.14 Stretch the release line. Position the red ball approx. 200 mm outside the fitting and lock it with a stopping knot. Bury the knot in the cavity of the ball. Cut off the spare rope and melt the end.
- 2.15 Tension the rubber cord until a slight "resistance" is noticed. Pull a further 500mm and mark where the cord exits the fitting. Lock the cord temporarily with a knot. Cut the cord at the mark and fit the ring using the knot shown in fig. 3. Cut off excessive cord and melt the end.
- 2.16 Slide the inboard savers into position as shown in fig. 1 and lock them by deforming the groove at the ends of the savers using a screwdriver. Note how the outboard savers are locked, see fig. 4.

Fig. 3



Fig. 4

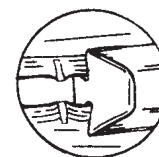

72/72 AND 84/84

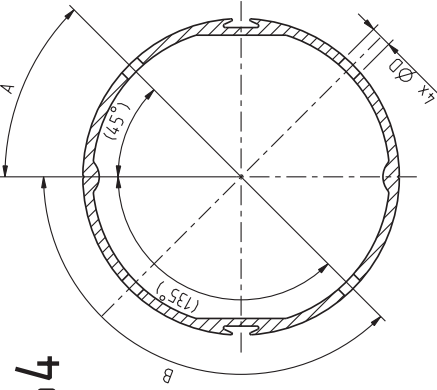

SECTION	A	B	C
72/72	29	86	90
84/84	33	99	105

D (HOLE DIAMETER)	
RIVET	SCREW (SPINN. POLE KIT)
Ø4.9	Ø4

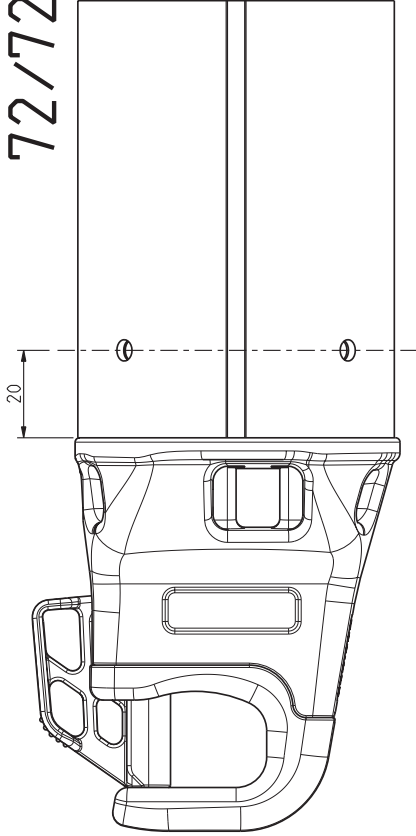

96/96

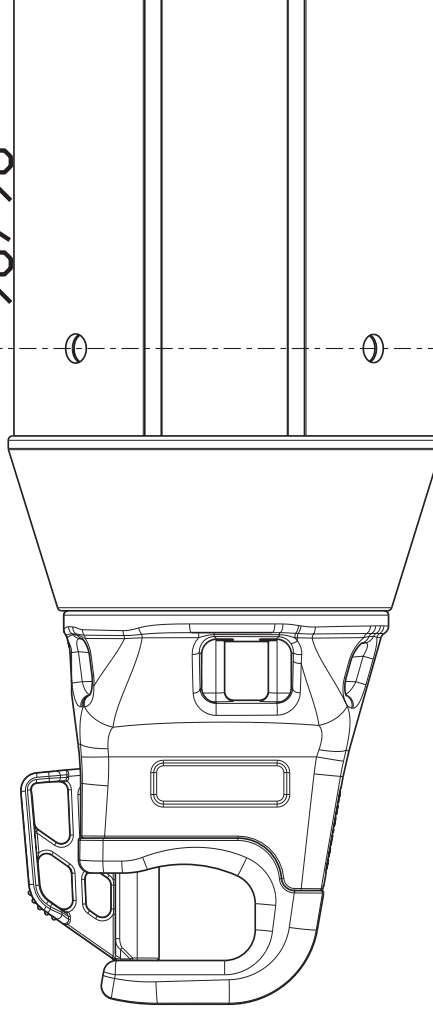
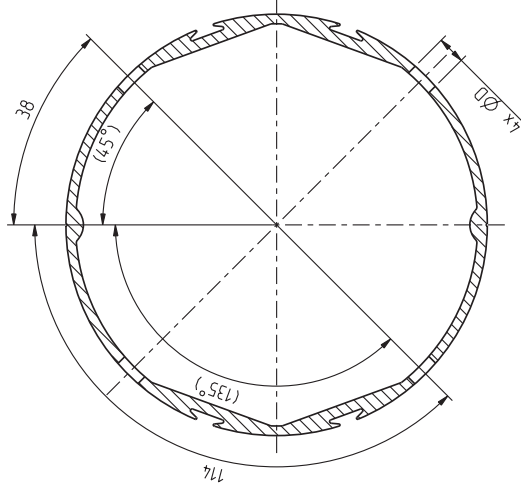

D (HOLE DIAMETER)	
RIVET	SCREW (SPINN. POLE KIT)
Ø6.5	Ø4

Item	Qty	Description	Dimension	Part No.
SELDÉN				
LOCATION FASTENERS SPINN POLE END 534-854				
Tolerance acc. to SS-ISO 2768-c unless otherwise stated		Replaced by	Release	Revision
Drawn	JG	Date	06-07-06	Scale
		Releasing	Approved	Part No.
				3050
				PS736

No	Qty	Revision	Date	Sign

DINGHIES KEELBOATS YACHTS

Seldén Mast AB, Sweden
Tel +46 (0)31 69 69 00
Fax +46 (0)31 29 71 37
e-mail info@seldenmast.com

Seldén Mast Limited, UK
Tel +44 (0) 1329 504000
Fax +44 (0) 1329 504049
e-mail info@seldenmast.co.uk

Seldén Mast Inc., USA
Tel +1 843-760-6278
Fax +1 843-760-1220
e-mail info@seldenus.com

Seldén Mast A/S, DK
Tel +45 39 18 44 00
Fax +45 39 27 17 00
e-mail info@seldenmast.dk

Seldén Mid Europe B.V., NL
Tel +31 (0) 111-698 120
Fax +31 (0) 111-698 130
e-mail info@seldenmast.nl

Seldén Mast SAS, FR
Tel +33 (0) 251 362 110
Fax +33 (0) 251 362 185
e-mail info@seldenmast.fr

www.seldenmast.com

Dealer:

The Seldén Group is the world's leading manufacturer of masts and rigging systems in carbon and aluminium for dinghies, keelboats and yachts.

The Group consists of Seldén Mast AB in Sweden, Seldén Mast A/S in Denmark, Seldén Mast Ltd in the UK, Seldén Mid Europe B.V. in the Netherlands, Seldén Mast Inc in the USA and Seldén Mast SAS in France. Our well known brands are Seldén and Furlex. The worldwide success of Furlex has enabled us to build a network of over 750 authorised dealers covering the world's marine markets. So wherever you sail, you can be sure of fast access to our service, spare parts and know-how.

