

# ***CXe 25 & CXe 45***

**Manual for assembly and operation**

**TD & OD**

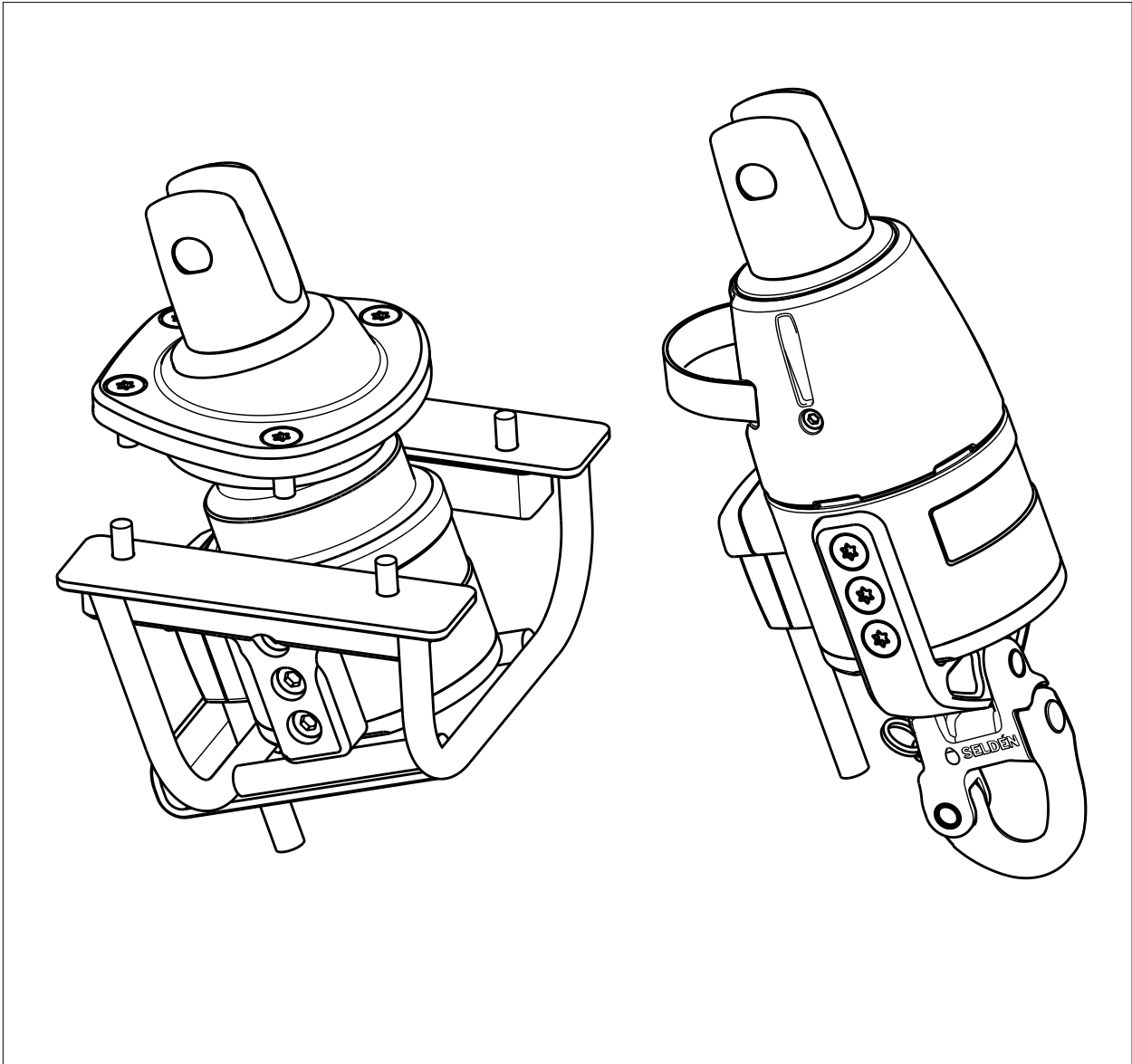

# Introduction

Congratulations on the purchase of your new Seldén CXe electric Code 0 furler.

This manual covers installation and operating instructions for CXe 25/45 TD (through deck) and CXe 25/45 OD (on deck).

Please read the entire manual before assembly/usage and keep the manual available for future reference. The latest version is available at [www.seldenmast.com](http://www.seldenmast.com).

## Related installation manuals and user guides:

Power supply and SEL-Bus system: Manual 597-275-E

## Safety precautions



This symbol indicates a delicate moment in the assembly or a technical advice.



This symbol indicates a potential hazardous situation which, in the event of failure, can lead to damages to property, personal injury or death.

## Choosing the correct version of furler for your boat:

The key to a safe and properly working installation is correct dimensioning in relation to the boat size the products shall be used on. Seldén provides dimensioning guidelines in catalogues, leaflets and on the website. If there are any questions about selecting the right product, please consult an authorized Seldén dealer. All dealers are listed at [www.seldenmast.com](http://www.seldenmast.com).

## Safety notes regarding the electrical installation for the CXe:

-The installation should be done by a person with marine installations skills. You can find your local authorized Seldén dealer at [www.seldenmast.com](http://www.seldenmast.com).

-CXe is controlled only by Seldén's 42V motor drive system.

-Make sure the system is switched off before performing any installation or service.

-Never modify the electric system of your CXe or its installation drawings - installation, alterations and maintenance should be performed by a competent marine electrician.

-Never alter or modify the rated current amperage of overcurrent protective devices.

-Never leave the craft unattended with the CXe energized.

# Contents

	page
1 Introduction .....	2
2 Presentation .....	4
2.1 Basic Packs for CXe complete kit .....	4
2.2 Control pack.....	5
2.3 Optional parts .....	6
2.4 Technical specification .....	7
3 Drive unit installation CXe TD through deck .....	8
3.1 Assembly preparations .....	8
3.2 Deck cut-out.....	9
4 Installation .....	12
4.1 Fitting the deck collar .....	12
4.2 Fitting the drive unit .....	12
4.3 Assembly of the collar .....	14
4.4 Assembly of the drive unit .....	15
5 Drive unit installation CXe TD through bow sprit .....	16
5.1 Assembly preparations.....	16
5.2 Deck cut-out .....	17
6 Installation .....	18
6.1 Fitting the deck collar .....	18
6.2 Fitting the drive unit .....	18
6.3 Assembly of the deck collar .....	19
6.4 Assembly of the drive unit .....	20
7 Electrical installation .....	22
7.1 Assembly of the deck contact housing and power cable .....	22
7.2 Assembly of connector .....	23
7.3 Connection to Seldén Power supply and SEL-Bus system .....	24
8 Operation .....	25
8.1 Normal operation .....	25
8.2 Unfurling .....	25
8.3 Furling .....	26
8.4 Securing the system .....	26
8.5 Emergency furling .....	26
9 Trouble shooting .....	27
10 Service and Maintenance .....	28
10.1 Frequent maintenance.....	28
10.2 Yearly Inspection points and maintenance .....	28
11 Technical Information .....	29
12 Disposal .....	29
13 Warranty .....	29

## 2. CXe

CXe is a two-speed electric furler for Code sails and with a Selden tack adaptor also for top-down furling gennakers. CXe is available as an on-deck (designated OD) and through deck installation (designated TD).

### Low power consumption

High efficiency throughout the electric power and control system. A “sleep mode” is activated to save power when not in operation.

### Powerful enough, but with precise torque limitation.

The electric motor has a computerised controller that monitors the current draw precisely. As soon as it reaches a pre-set level it cuts out quickly enough to avoid damage to components. The torque level is programmed into a memory chip.

### Resistant to the marine environment

CXe uses anodized 6000-series aluminium components. Plastic components are PC and PA, glass fibre reinforced and UV stabilized. The motor and reduction gear operates in the oil filled and sealed aluminium housing. The drive units are individually pressure tested before delivery.

A double seal between deck collar and drive unit prevents water intrusion (TD)

### Two speed operation

A double control button makes it possible to operate the furler with great precision in the low speed mode. By pushing both buttons at the same time, high speed is activated.

### Limited brake

The reduction gear and motor gives a limited brake function but will not protect against involuntary unfurling. See chapter 8 for more information.

### Compact size. Minimized weight and dimensions.

The electric motor is compact, still giving enough power. This is made possible by raising the voltage up to 42V. Keeping weight and the dimensions in focus during the design has resulted in a small unit.

## 2.1 Basic Packs for CXe45 complete kit

		CXe25 OD	CXe25 TD	CXe45 OD	CXe45 TD
Parts included	Qty	545-455-18	545-455-28	545-455-20	545-455-30
Drive unit	1	545-455-09	545-455-10	545-455-11	545-455-12
Deck collar assembly	1	-	545-465-01	-	545-465-01
Insulators	2	-	530-778	-	530-778
Screws M8x40	4	-	153-008	-	153-008
Bag	1	596-196	-	596-196	-
Deck connector kit	1	532-830-01	-	532-830-01	-
Deck connector housing with support	1	532-833-01	-	532-833-01	-
Manual	1	597-963-E	597-963-E	597-963-E	597-963-E

## 2.2 Control pack

CXe is used together with the Seldén Power supply and SEL-Bus system. The drive unit is connected to a motor control unit (MCU), which enables communication with the power supply unit and the OUT/IN push buttons. The CXe is either connected to an existing SEL-Bus system onboard (only requiring an additional MCU (Motor Control Unit), push buttons and SEL-Bus converter) or sold as a complete system.



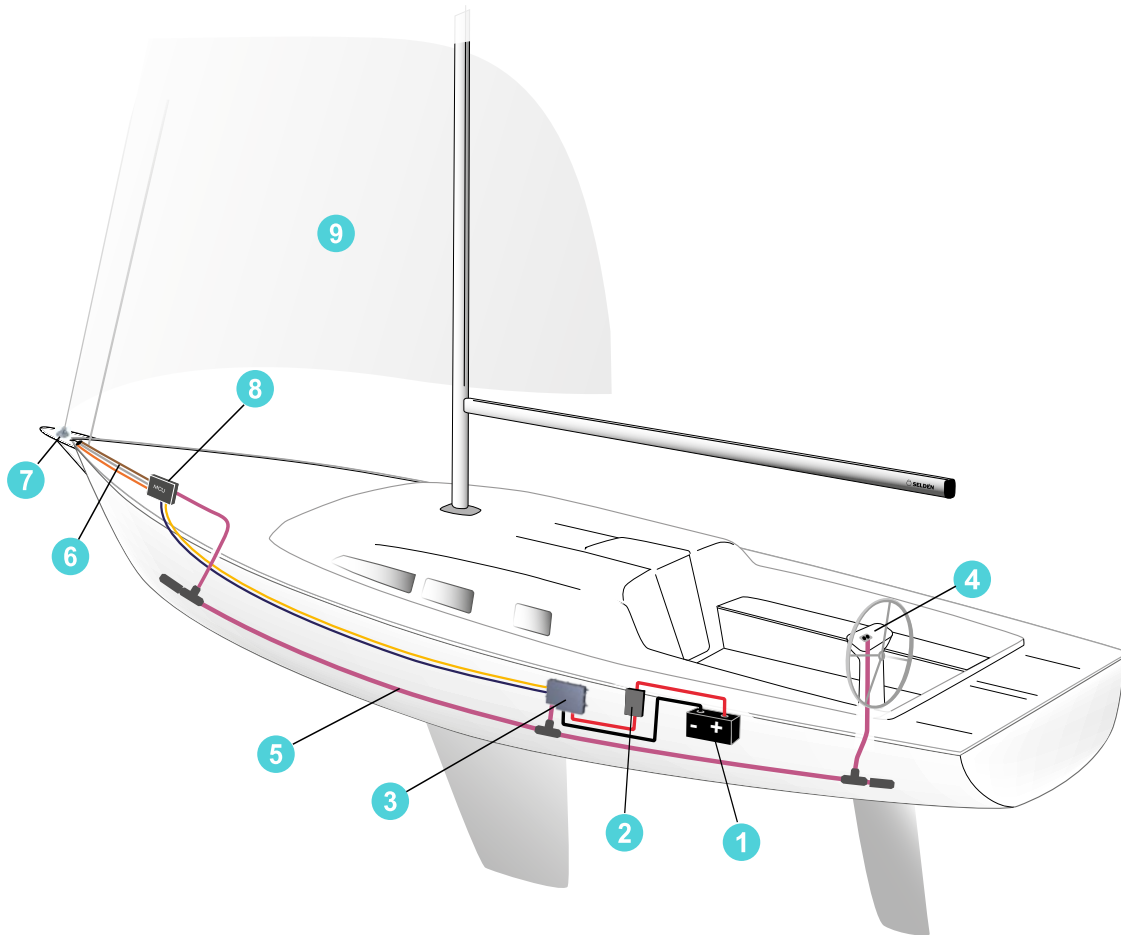







All power supply and SEL-Bus system parts are sold separately. Parts and packages are described in Seldén Power Supply and SEL-Bus system: Order guide 597-283-E. For installation of the Power Supply and SEL-Bus system, see installation guide 597-275-E. System illustration.

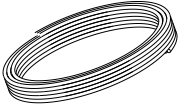

- |   |  |                                 |
|---|--|---------------------------------|
| 1 Battery (not sold by Seldén)                      | 4 Push buttons for CXe                                   | 7 CXe TD or OD Code 0 furler    |
| 2 Main switch/fuse                                  | 5 SEL-Bus backbone cables and connections                | 8 Motor Control Unit (MCU), CXe |
| 3 Power supply unit (PSU)<br>Converts 12/24V to 42V | 6 Connection cables, 3x5m<br>(Delivered with drive unit) | 9 Code 0 sail                   |

## 2.3 Optional parts

Parts that adapt your installation to your individual boat.

Item	CXe 25	CXe 45
	Art. No.	
Halyard swivel 	545-207-01	545-435-01
Block for 2:1 halyard 	405-501-01R	405-501-01R
Dead-end fitting 	508-844-01R (ø14) 508-838-01R (ø16)	
AT Cable, ø15 mm 	Ø13 613-022-01 16000mm 613-022-02 19000mm 613-022-03 22000mm 613-022-04 25000mm 613-022-05 28000mm	Ø15 613-023-01 19000mm 613-023-02 22000mm 613-023-03 25000mm 613-023-04 28000mm
Thimble kit 	545-216-01	545-416-01
AT clamp kit 	301-312-01	301-313-01
Protective cage/ Anchor guard 	545-468-01 1)	
SEL-Bus Converter (for custom control buttons) 	532-827-01	
Panel, 1 push button 	540-461-01	
Panel, 2 push buttons 	540-461-01	
Deck connector kit 2) 	532-830-01	
Deck connector housing with support 2) 	532-833-01	

1) CXeTD only

2) Included in CXe OD basic packs.

## 2.4 Technical specifications

	CXe 25/45
Input voltage to motor control unit	42V
Peak Torque	50 Nm
Peak Current Consumption [42V]	25A
Total Gear Ratio	19:1
Low Speed (unloaded)	220 rpm
High Speed (unloaded)	500 rpm
Efficiency (Motor Control Unit + Drive Unit)	80%
Electric cable between drive unit and motor control unit	3x6 mm <sup>2</sup> , ø11,5 mm

### Main dimensions, mm.

	CXe 25	CXe 45
Pin ø (D1)	12	16
Fork width (W1)	21	22
Fork depth (D2)	32	34
Width (W2)	106	106
Height (H1)	285	300
Width (W3)	149	149
Height (H2)	140	140
Width (W4)	132	132
T (Deck thickness)	50	50

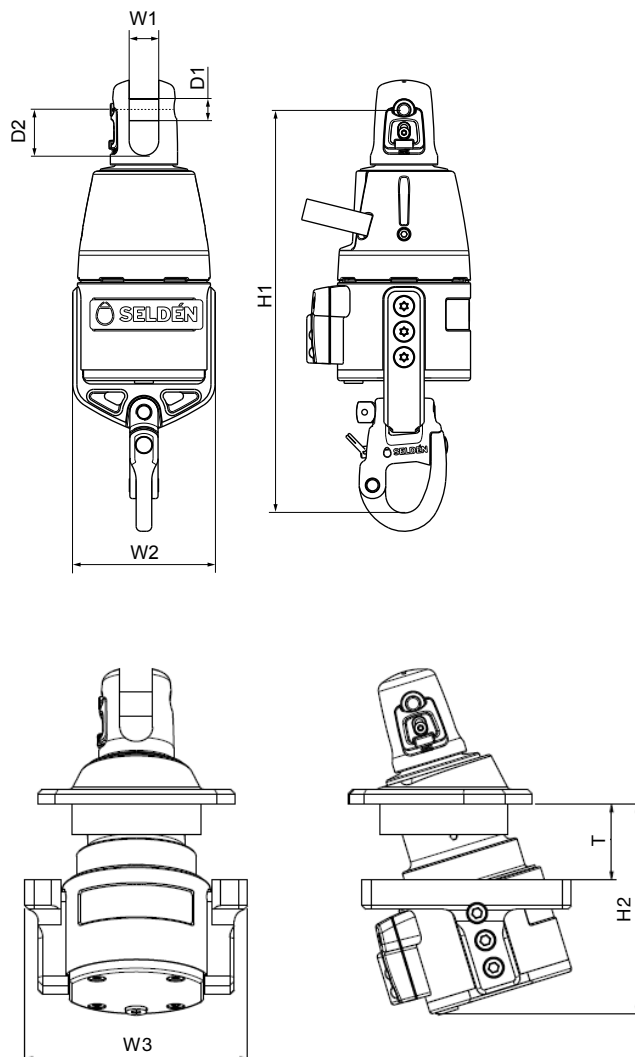

# 3 Drive unit installation CXe TD through deck.

Chapter 3 & 4 cover installation in laminated deck or wooden deck. For installation in stainless bow sprits or other metal designs -see to chapter 5.

## 3.1 Assembly preparations



Always use protective goggles, gloves, dust mask and ear protection when working with power tools and in a dusty environment.

### Space requirements

-Check so that there is enough space for the installation. The dimensions are given in the section "2.4 Technical Specification".

-Note that the deck needs to have a thickness of 50 mm (2") at the two brackets.

-The deck needs to be reasonably flat within the outline of the deck collar for a good fit and seal.

-The drive unit has a built in angle of 73°. Angle between AT-cable and deck must be 73°±2°. Make a simple template and use halyard to check angle. Adjust surface under deck collar if necessary.



-Do not use the deck collar and bracket insulators. Used only when deck material is metal.

### Strength of the deck

Make sure the deck is solid around the drive unit and can handle the load.

Max service load (MSL): CXe 25: 25kN, CXe 45: 45kN.

### Tools required:

-Tape measure.

-Fine marking pen.

-Cloth tape.

- ø86 mm hole saw or jigsaw.

-ø3-4 mm drill bit for pilot holes.

-ø6.8 mm drill bit for M8 or drill bit for 5/16 thread if imperial screws are used.

-4x countersunk screws 5/16" in A4/316L quality. Length 1".

-4x socket head cap screws 5/16" in A4/316L quality. Length 1 3/16"

All necessary screws (M8) are included in the kit.

-Set of Torx and Hex bits.

-Files-half round and round

-Structural fiberglass putty, wood or other suitable material for adjusting deck thickness if necessary.

-Caulking

-Rubbing alcohol or other suitable cleaner.

-Marine type grease.

-Corrosion inhibiting compound (grease can be used)

-Threadlocker.



### 3.2 Deck cut-out.

#### 1.

Find the centerline of the boat and mark out the position of the  $\varnothing 86$  mm hole.

Drill a  $\varnothing 4-5$  mm pilot hole through center.

For deck thickness  $>20$  mm-drill an additional hole (A) 27 mm in front of first hole

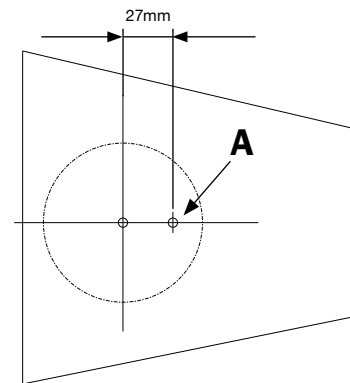

#### 2.

For deck thickness  $>20$  mm:

Using the forward hole as a guide, drill from below with the hole saw.



Drill depth: Deck thickness-20 mm.

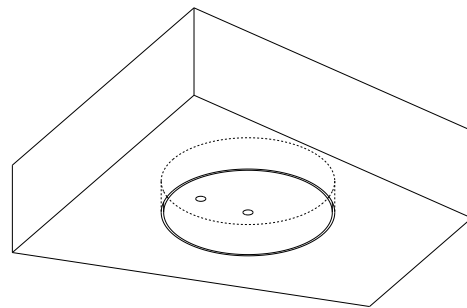

#### 3.

Use hole saw or jig saw to make the center hole.

Take caution when using a jig saw not making the hole too large.

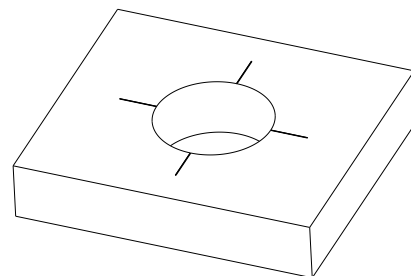

#### 4.

Remove forward portion of deck if applicable. See next chapter for more details

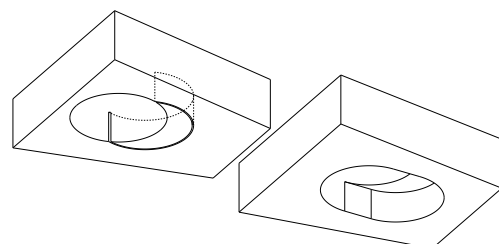

## 5.

Adjust deck thickness and add clearance.  
Examples of different deck thickness and required modifications shown.

Seen from below.

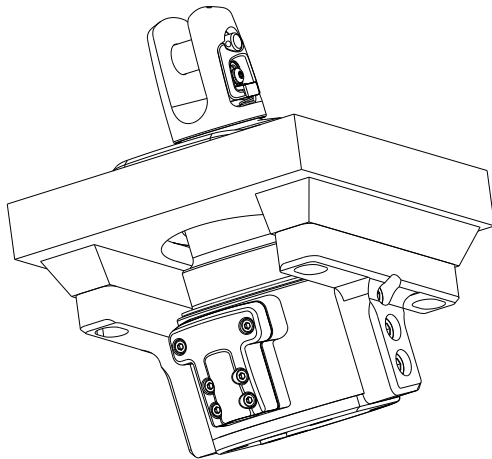
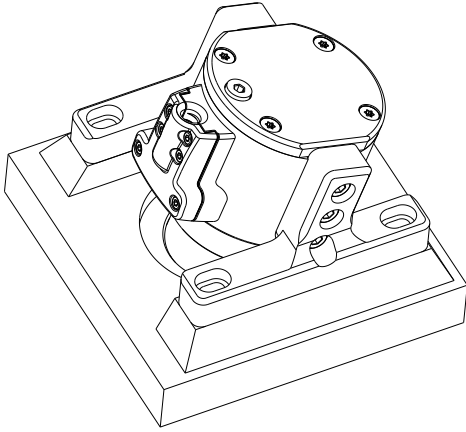

 Reduce deck thickness by 4 mm if protective cage 545-468 is used.

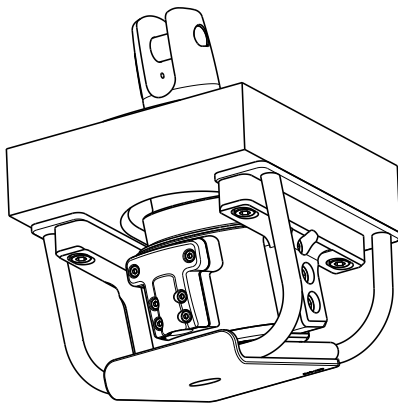

50 mm thickness shown as marked areas.

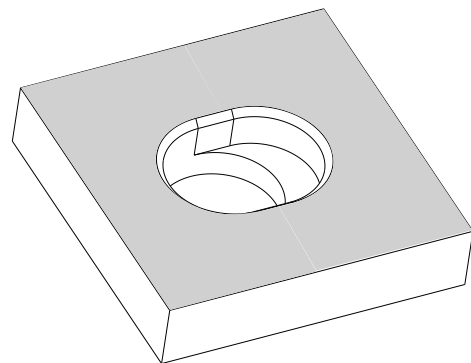
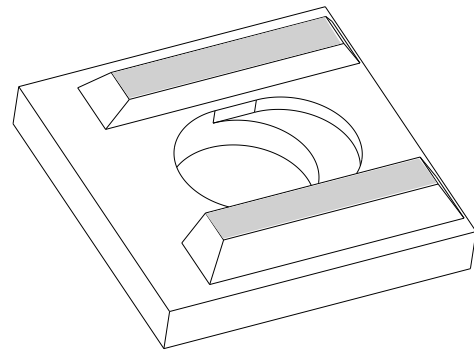
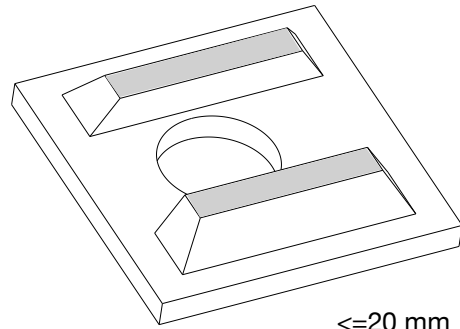

50 mm. Chamfer necessary.

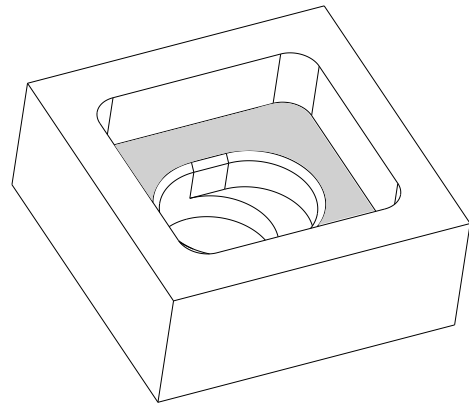

>50 mm

**6.**

Make a simple template to ensure position/flatness of mounting surfaces using the deck as reference.

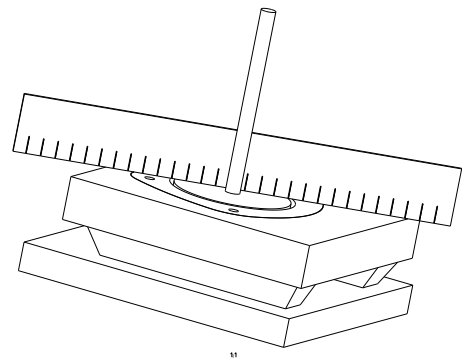
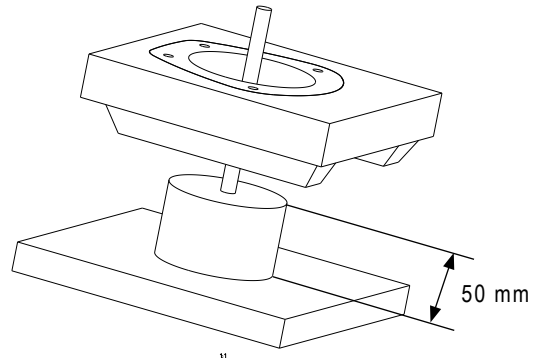

## 4. Installation

### 4.1 Fitting the deck collar

#### 1.

Adjust the hole for deck collar if necessary. Fit should be as tight as possible. Adjust hole with putty if necessary. Use release agent or tape on deck collar if used as template.

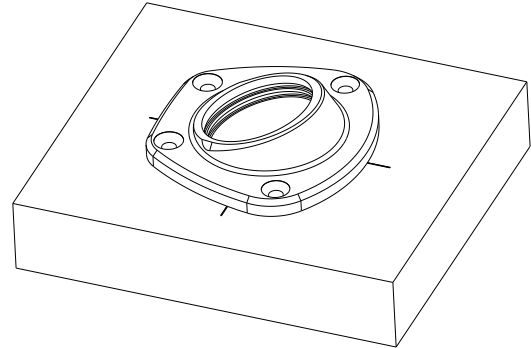

#### 2.

Align the deck collar and mark out the four screw holes using the deck collar as template. Remove the deck collar.

Drill and tap the four screw holes M8 or 5/16. 15mm full thread (drill depth~20 mm)

The aft holes can be through holes with washer and nut if desired. In this case custom length of the screws is required.

Test fit the deck collar. Do not tighten screws fully.

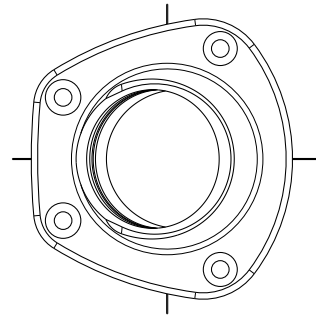

### 4.2 Fitting the drive unit

#### 1.

Insert the drive unit from below

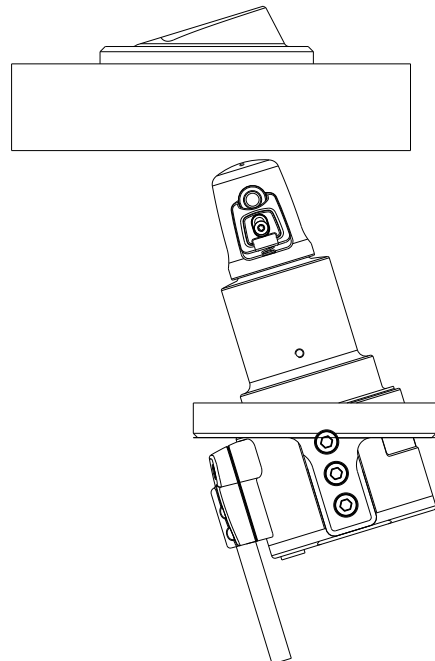

**2.**

Make sure the brackets fully mate with the mounting surfaces in the deck and that there is no interference between the drive unit and the deck. Adjust if necessary. Check that the top surface of the drive unit is slightly higher than the top surface of the deck collar. (A)

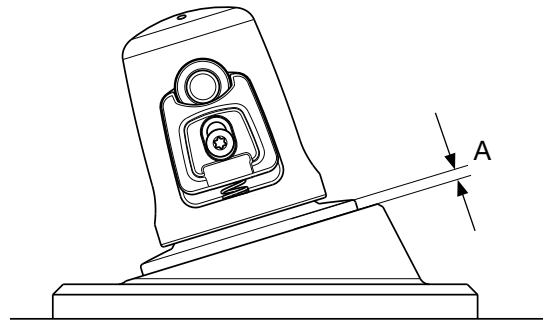

**3.**

Mark out the positions for the 4 bracket screws with a pen.

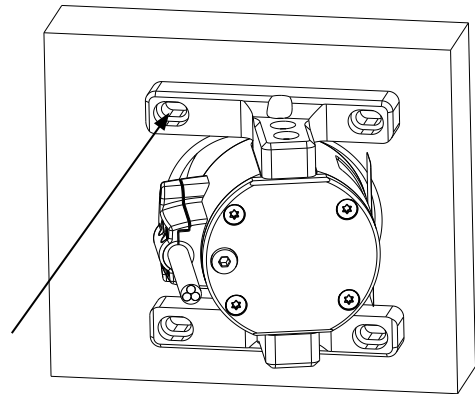

**4.**

Remove the drive unit. Drill and tap the four holes M8 or 5/16. 20 mm full thread min (drill depth ~25 mm)

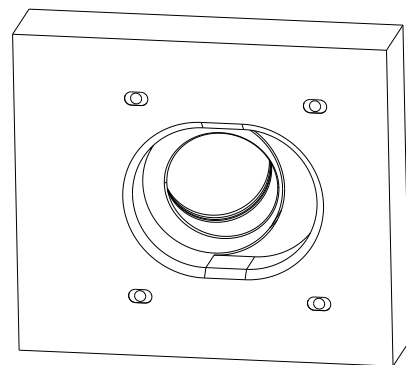

**5.**

Test fit the drive unit with all four screws. Do not tighten fully. Remove the drive unit.

### 4.3 Assembly of the collar

#### 1.

Remove the deck collar. Clean the deck and mating surface of the deck collar with solvent.

Apply caulking around center hole and screw holes. Also apply caulking to loop and fit it in the recess in the deck collar.

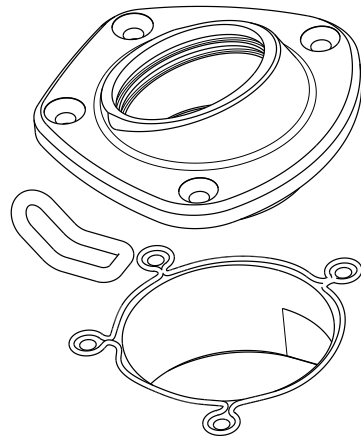

#### 2.

Fit the collar, loop and screws. Using caulking or other compound under the screw heads will prevent corrosion.

Wipe off any excess.

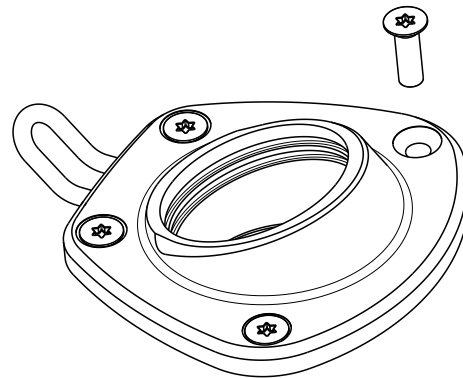

## 4.4 Assembly of the drive unit

### 1.

Fit the two O-rings in the grooves in the deck collar.

Apply a thin layer of grease on the O-rings.

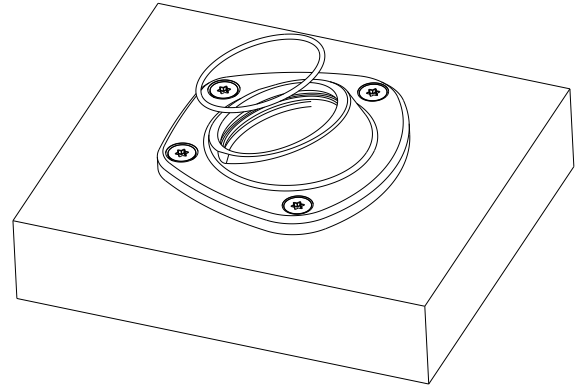

### 2.

Insert the drive unit carefully making sure the O-rings are not dislocated.

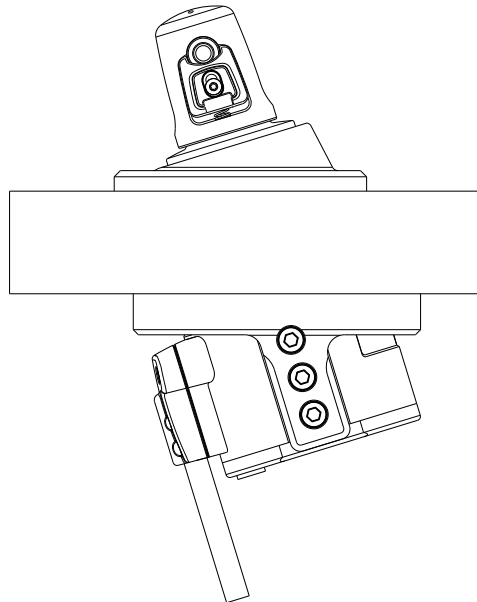

### 3.

Fit and tighten the screws. Use locking adhesive

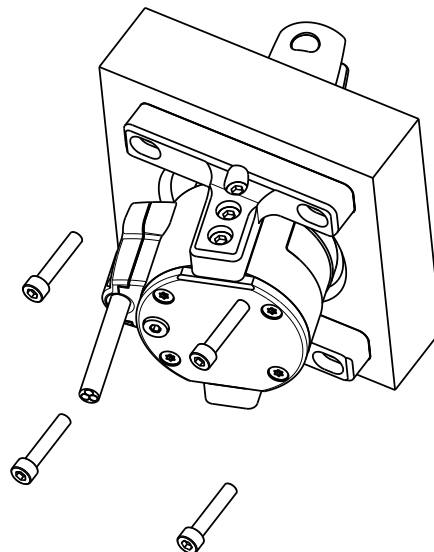

# 5. Drive unit installation CXe TD through bow sprit.

This chapter covers installation in stainless bow sprits or other metal designs

## 5.1 Assembly preparations



Always use protective goggles, gloves, dust mask and ear protection when working with metal.

### Space requirements

-Check so that there is enough space for the installation. The dimensions are given in the section "2.4 Technical Specification".

-Note that the design needs to have a thickness of 44-48 mm at the two brackets.

-Weld nuts can replace tapped holes.

-The drive unit has a built in angle of 73°. Angle between AT-cable and bow sprit must be 73°±2°. Make a simple template and use halyard to check angle. Adjust surface under deck collar if necessary.



-Always use the deck collar and bracket insulators to prevent corrosion when drive unit is fitted in metal designs.

### Strength of the bow sprit.

Make sure the bow sprit and area around drive unit can handle the load.

Max service load (MSL): CXe25: 25kN, CXe45: 45kN.

### Tools required:

-Tape measure.

-Fine marking pen.

-Cloth tape.

- Hole saw or other suitable tool for making the ø88mm hole.

-ø3-4 mm drill bit for pilot holes.

-ø6.8 mm drill bit for M8 or drill bit for 5/16 thread if imperial screws are used.

-4x countersunk screws 5/16" in A4/316L quality. Length 1".

-4x socket head cap screws 5/16" in A4/316L quality. Length 1 3/16"

All necessary screws (M8) are included in the kit.

-Set of Torx and Hex bits.

-Files-half round and round

-Marine type grease

-Corrosion inhibiting compound (grease can be used)



**1.**

Find the centerline of the bowsprit and mark out the position of the  $\varnothing 88$  mm hole.

Drill a  $\varnothing 4-5$  mm pilot hole through center.

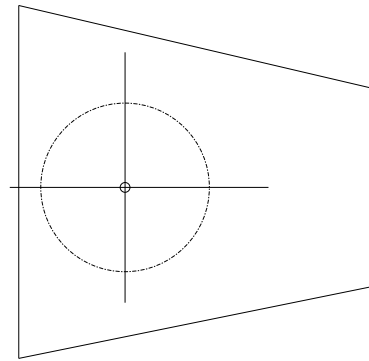

**2.**

Use hole saw or jig saw to make the center hole.

Take caution when using a jig saw not making the hole too large.

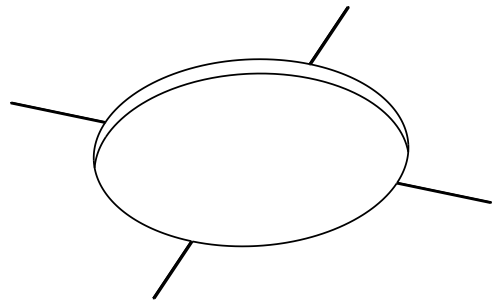

**3.**

Adjust the distance between deck and mounting surfaces.



Note that the dimension varies depending on if the protective cage is to be used or not.

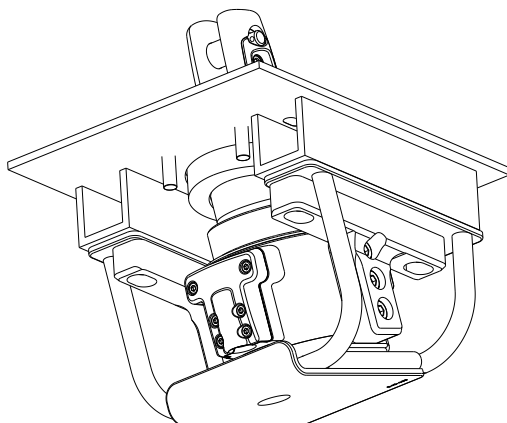

44 mm thickness with protective cage.

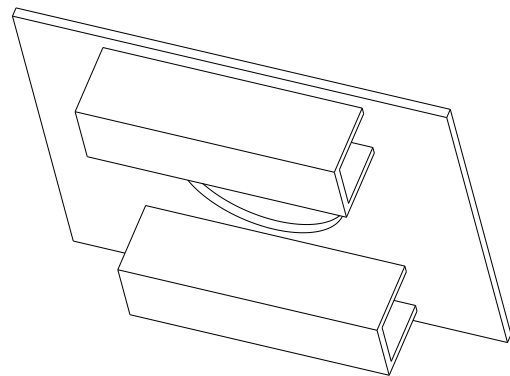

# 6 Installation

## 6.1 Fitting the deck collar

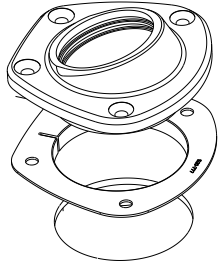
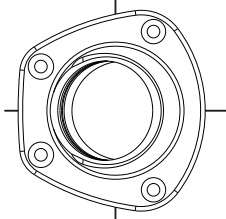
<p><b>1.</b></p> <p>Fit the insulator to the deck collar and mount it in the hole.</p> <p>Adjust the hole for if necessary. Fit should be as tight as possible.</p>	
<p><b>2.</b></p> <p>Align the deck collar and mark out the four screw holes using the deck collar as template. Remove the deck collar.</p> <p>Drill and tap the four screw holes M8 or 5/16.</p> <p>Test fit the deck collar. Do not tighten screws fully.</p>	

## 6.2 Fitting the drive unit

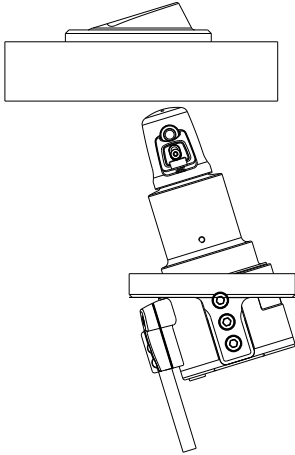
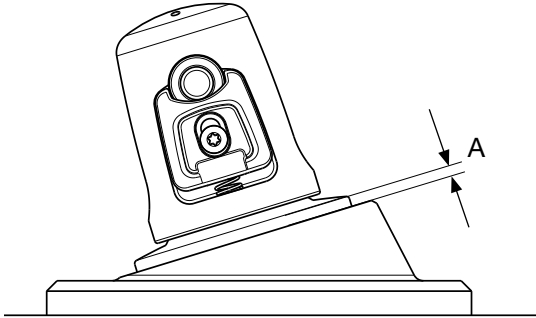
<p><b>1.</b></p> <p>Insert the drive unit from below</p>	
<p><b>2.</b></p> <p>Make sure the brackets fully mate with the mounting surfaces in the bow sprit and that there is no interference. Adjust if necessary. Check that the top surface of the drive unit is slightly higher than the top surface of the deck collar. (A)</p>	

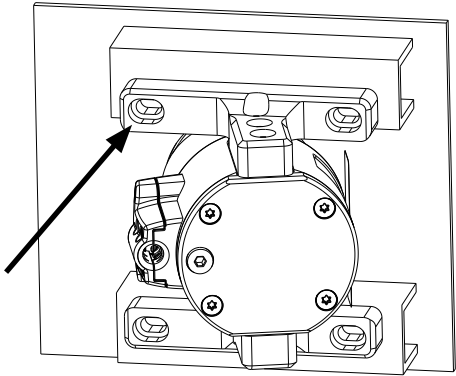
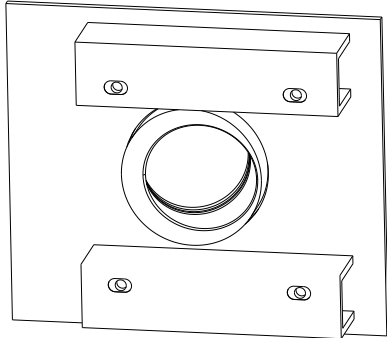
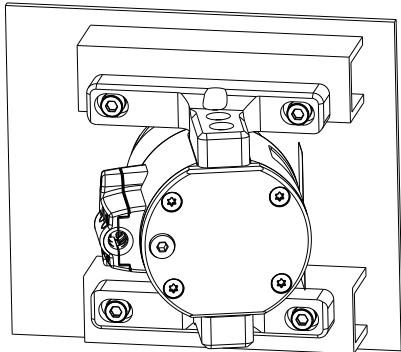
<p><b>3.</b></p> <p>Mark out the positions for the 4 bracket screws with a pen.</p>	
<p><b>4.</b></p> <p>Remove the drive unit. Drill and tap the four holes M8 or 5/16.</p> <p>Drill clearance holes if nuts are used.</p>	
<p><b>5.</b></p> <p>Test fit the drive unit with all four screws.</p> <p>Do not tighten fully. Remove the drive unit.</p>	

### 6.3 Assembly of the deck collar

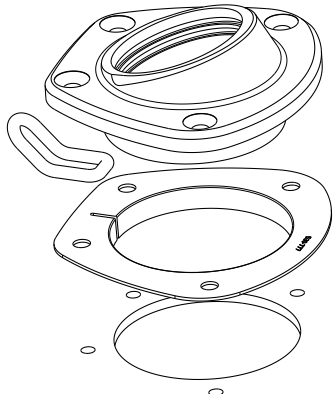
<p><b>1.</b></p> <p>Remove the deck collar and insulator.</p> <p>Apply caulking to the loop and fit it in the recess in the deck collar. Apply corrosion inhibiting compound to mating surfaces.</p>	
--	--

**2.**

Re-fit the parts and fit the screws. Use locking adhesive.

Using caulking, grease or other compound under the screw heads will prevent corrosion.

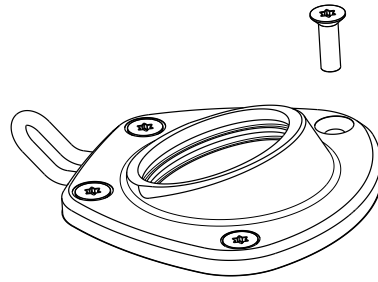

**6.4 Assembly of the drive unit**

**1.**

Fit the two O-rings in the deck collar.  
Apply a thin layer of grease on the O-rings.

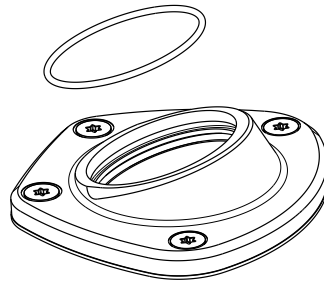

**2.**

Fit the bracket insulators. Apply corrosion inhibiting compound to mating surfaces.

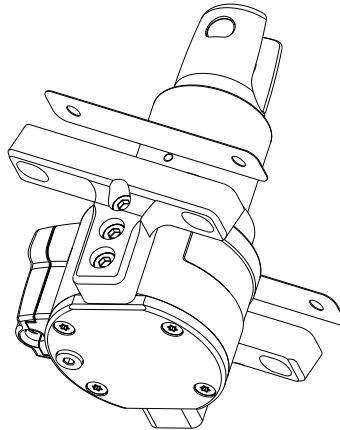

**3.**

Insert the drive unit carefully making sure the O-rings are not dislocated.

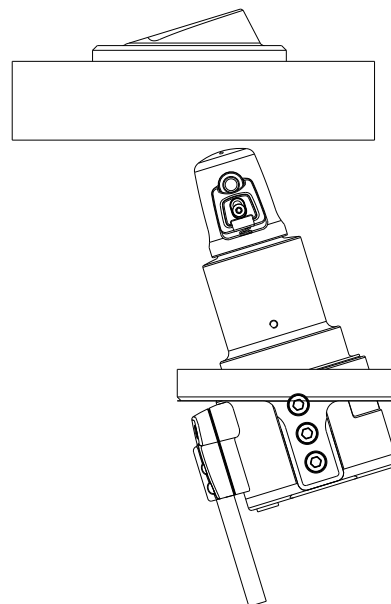

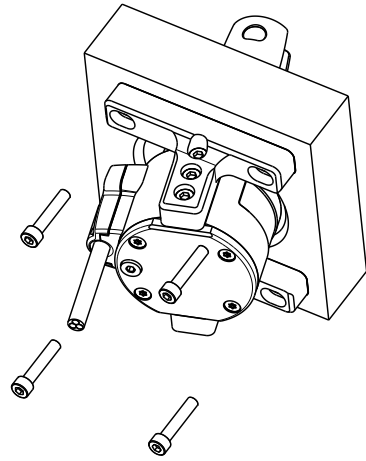

**4.**

Fit and tighten the screws.  
Use locking adhesive.

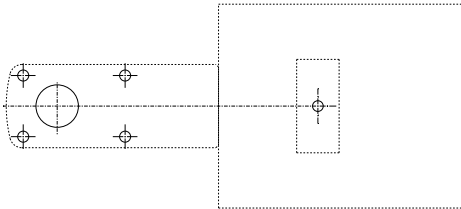

# 7 Electric installation

## 7.1 Assembly of the deck contact housing and power cable.

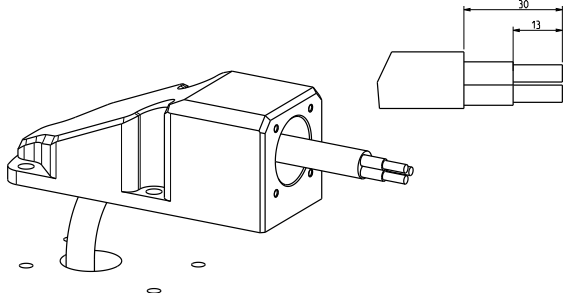
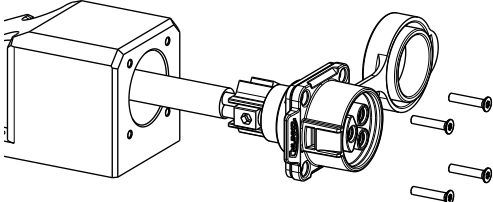
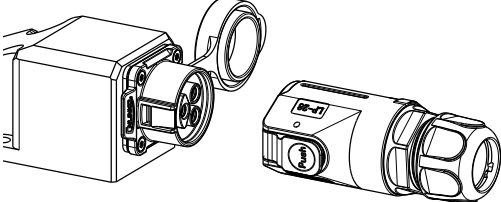
<p><b>1.</b></p> <p>Use template 597-967 to mark out the positions for the contact housing and the support. Mark out the positions for the holes. The drive unit has a 5m cable so this distance must not be exceeded.</p>	
<p><b>2.</b></p> <p>Drill the <math>\varnothing 25</math> mm hole using a hole saw. Remove any sharp edges. Drill and tap the five holes M6 for the screws supplied. Alternatively, adapt holes for any suitable 6 mm or 1/4" screws in marine grade 316 steel.</p>	
<p><b>3.</b></p> <p>Route the cable through the deck or bulkhead.</p> <p>Remove ~30 mm of the outer insulation.</p> <p> Be careful not to damage the insulation of the power cables. If damaged, cut cable and start over.</p> <p>Remove ~13 mm of the insulation of the power cables.</p> <p>Route the cable through the housing.</p>	
<p><b>4.</b></p> <p>Apply dielectric grease/petroleum jelly to the cable strands and connect them to any of the terminals in the socket. Tighten the grub screws firmly.</p> <p>It's recommended to use crimp terminals on the power cables. Max <math>\varnothing</math> 5 mm.</p>	
<p><b>5.</b></p> <p>Carefully insert the socket assembly in the housing. Apply anti corrosive compound to the screws and tighten. Note orientation. For left-hand operation-turn the socket assembly 180° in the housing.</p>	 <p>Right hand operation.</p>

## 6.

Apply caulking around holes and on mating surfaces. Carefully feed the cable through the deck. Fit the housing and tighten the screws.

Align the support and tighten the screw.

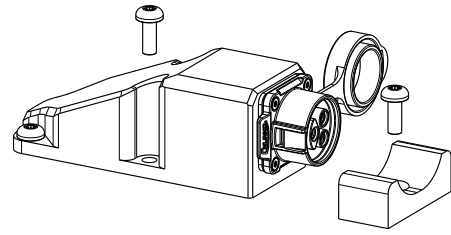

## 7.2 Assembly of connector

### 1.

Adjust the length of the power cable on the drive unit. Remove ~30 mm of the outer insulation.



Warning! Be careful not to damage the insulation of the power cables. If damaged, cut cable and start over.

Remove ~13 mm of the insulation of the power cables.

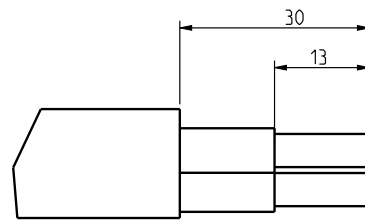

### 2.

Disassemble the connector. Start by unscrewing tail piece assembly (1) with grommet and nut from the body (2).

Push the lever (3) to release the terminal (4)

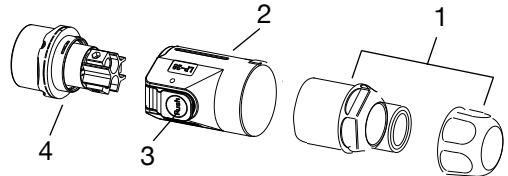

### 3.

Feed the tail piece assembly and body over the cable. Do not tighten the nut yet. Apply dielectric grease/petroleum jelly to the cable strands and connect them to any of the positions in the terminal. Tighten the grub screws firmly.

It's recommended to use crimp terminals on the power cables.

Max  $\varnothing$  5 mm.

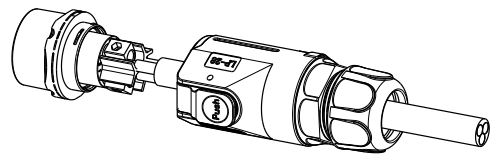

### 4.

Tighten the tail piece (5) to lock the terminal in the body.

Tighten the nut/grommet for a watertight assembly.

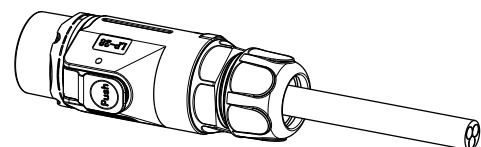

### 7.3 Connection to Seldén Power supply and SEL-Bus system



597-275-E

Connect the cables from the drive unit to the Furlex Electric Motor Control Unit contacts marked L1, L2, and L3 as shown in the picture below. For correct positioning of the Motor Control Unit and installation of the complete Power supply and SEL-Bus system, see separate manual 597-275.

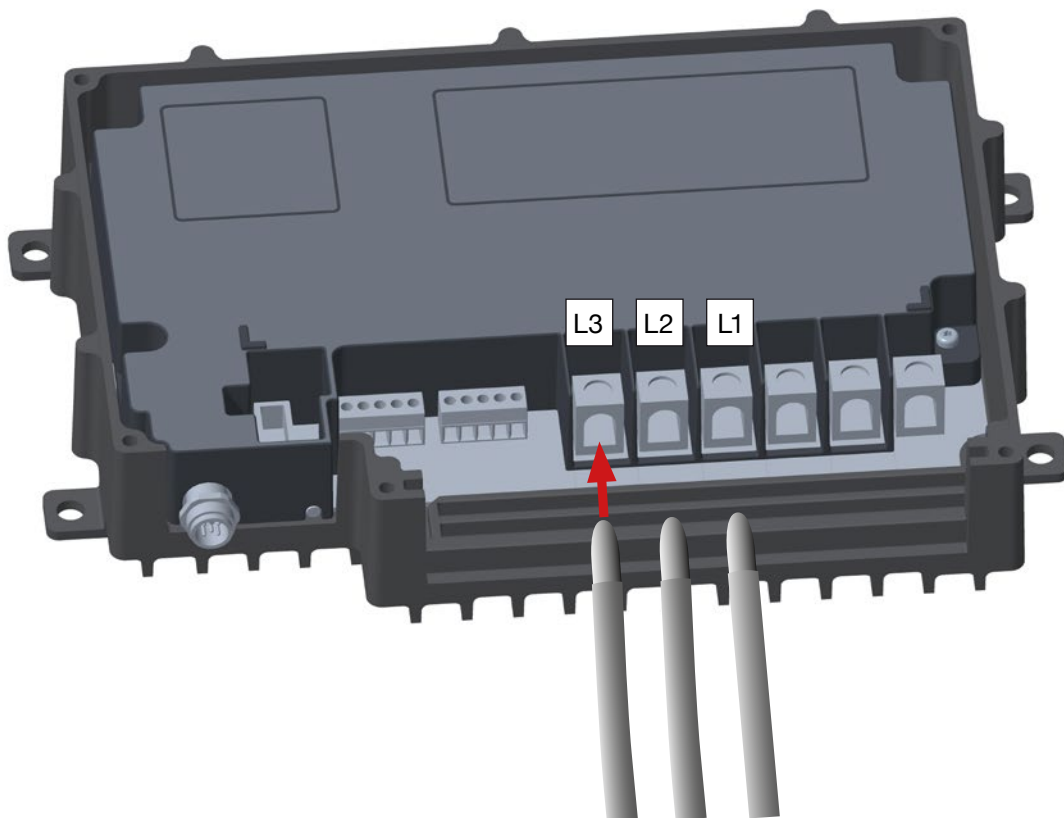

If opposite furling direction is desired (e.g. due to position of UV-protection in sail), this can be done by changing the position of cable to connector L2, and cable to connector L1.

Using crimp terminals on the cables will improve the connection between the cables and the control unit.



# 8 Operation

## 8.1 Normal operation

All operation modes require that the control current is turned on.



Always observe the furling process and ensure that nothing can interfere with the sail or its sheeting lines.

CXe operates with high or low speed.

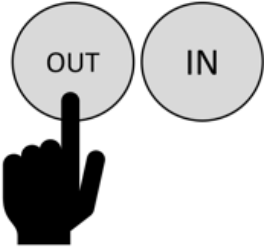
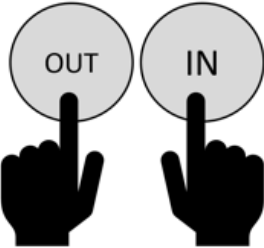
<h3>Low speed</h3> <p>Push either IN or OUT depending on which direction is required.</p>	
<h3>High speed</h3> <p>Whilst holding down the first button, depress the second button to increase to high speed.</p>	

## 8.2 Unfurling

1. Release the windward sheet. Allow it to run freely while the sail is being unfurled.
2. Place the leeward sheet with one turn around a winch and tension by hand.
3. Push the OUT-button and gradually tension the sheet. The sail will unfurl at low speed. For high speed, press the IN button simultaneously. Activate low speed when the sail is almost completely unfurled and then release the OUT-button. Holding the boat close hauled will ensure the best wind angle for unfurling.
4. Add more turns of the sheet around the winch and sheet the sail to the desired trim.

## 8.3 Furling

It is important to ensure a tight and even furl on the sail. A loosely furled sail can result in the sail flogging in heavy winds, causing wear and damage.

### How to furl

1. Release the windward sheet and ensure that it can run freely. Holding the boat close hauled will ensure the best wind angle for furling.
2. Release the leeward sheet but keep a little tension on it by keeping one turn around the winch.
3. Furl the sail by pushing the control button. Let it furl while keeping light resistance in the sheet.

## 8.4 Securing the system.

To prevent the system from unintentional unfurling always lock the system when left unattended. Connect a suitable strap between the loop in the deck collar and the thimble or fork as shown.

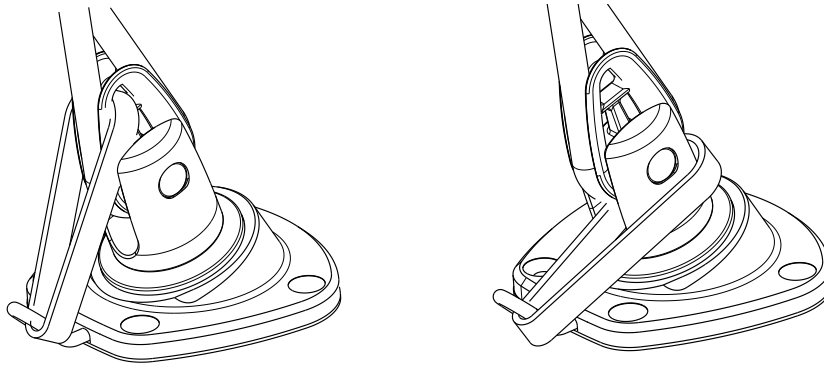

Never use CXe for sheeting.

## 8.5 Emergency furling

If power is lost the system will not operate. If sail is unfurled, release the tension in the sheet and try to get the sail behind the main sail before taking it down.

## 9 Trouble shooting

Problem	Probable Cause	Action
Furler not operating.	Electric failure or bad connection.	Troubleshoot the electric system.
Furler stops when heavily loaded.	Overload.	<ol style="list-style-type: none"> <li>1. Ease load and check if operation is OK.</li> <li>2. See operating instructions. If overloaded, the motor controller will limit the torque by cutting current supply to the motor.</li> </ol>
Furler runs in wrong direction.	The wires have not been properly installed.	If opposite furling direction is wanted: Choose any two of the three motor cables and swap their positions on the connecting box terminal.
Oil leakage	Defective seals in motor unit, or broken housing.	Contact your Seldén representative for service instructions.
Grease leakage	Defective seals in worm gear transmission, or broken housing.	Contact your Seldén representative for service instructions.

# 10 Service and Maintenance

In order for your CXe system to function both mechanically and electrically, year after year, a certain amount of system maintenance is required on a regular basis.

## 10.1 Frequent maintenance

- Wash and rinse the entire system with fresh water to remove dirt and salt residue. This also applies to a CXe TD located in an anchor box or in a bowsprit. Also check that the anchor box drainage functions satisfactorily.
- The stainless-steel components can be treated with a suitable polish. Always protect black plastic when polishing stainless components.



Some detergents contain substances which can cause aluminium to corrode, so it is important to rinse all detergent off thoroughly.

## 10.2 Yearly Inspection points and maintenance

- Check for leaks of oil or grease.
- Rinse with fresh water to remove dirt and salt if necessary. Aluminium surfaces can be protected by an anti-corrosion spray.
- Inspect the power cable and its connections for damages.

# 11 Technical Information

The Seldén Power Supply and SEL-Bus system, which has been tested according to standard EN 61800-3, meets the EMC directive 2014/30/EU. This product has also been tested according to standard EN 60945 and meets the limits of emissions for maritime equipment when in standby mode.

# 12 Disposal

The crossed out wheellie bin symbol on the product or product package means that used electrical and electronic equipment (WEEE) should not be mixed with general household waste. For proper treatment, recovery and recycling, please take this product(s) to designated collection points where it will be accepted free of charge. Alternatively, in some countries, you may be able to return your products to your local retailer upon purchase of an equivalent new product.

Disposing of this product correctly will help save valuable resources and prevent any potential negative effects on human health and the environment, which could otherwise arise from inappropriate waste handling.

Please contact your local authority for further details of your nearest designated collection point.

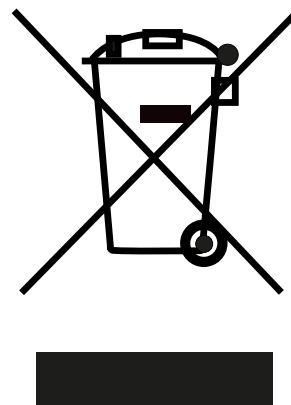

# 13 Warranty

Seldén Mast AB guarantees CXe for 2 years. The guarantee covers faults arising from defective design, materials or workmanship.

The guarantee is only valid if the product is assembled, operated and maintained in accordance with this manual and is not subjected to loads in excess of those indicated in the brochure and on the Seldén website.

Complete shipment and warranty conditions are to be found on Seldéns website [www.seldenmast.com](http://www.seldenmast.com). See [www.seldenmast.com/general-conditions-of-sale/](http://www.seldenmast.com/general-conditions-of-sale/).

If the system is repaired or modified by anyone other than Seldén Mast AB or one of our authorized dealers, the guarantee ceases to be valid.

Seldén Mast AB reserves the right to alter the content and design without prior warning.





# DINGHIESKEELBOATSYACHTS

**Seldén Mast AB, Sweden**  
Tel +46 (0)31 69 69 00  
e-mail [info@seldenmast.com](mailto:info@seldenmast.com)

**Seldén Mast Limited, UK**  
Tel +44 (0)1329 50 40 00  
e-mail [info@seldenmast.co.uk](mailto:info@seldenmast.co.uk)

**Seldén Mast Inc., USA**  
Tel +1 843-760-6278  
e-mail [info@seldenus.com](mailto:info@seldenus.com)

**Seldén Mast A/S, Denmark**  
Tel +45 39 18 44 00  
e-mail [info@seldenmast.dk](mailto:info@seldenmast.dk)

**Seldén Mid Europe B.V.,  
Netherlands**  
Tel +31 (0)111-698 120  
e-mail [info@seldenmast.nl](mailto:info@seldenmast.nl)

**Seldén Mast SAS, France**  
Tel +33 (0)251 362 110  
e-mail [info@seldenmast.fr](mailto:info@seldenmast.fr)

The Seldén Group is the world's leading manufacturer of mast and rigging systems in carbon and aluminium for dinghies, keelboats and yachts.

Our well known brands are Seldén and Furlex.

The worldwide success of Furlex has enabled us to build a network of over 750 authorised dealers covering the world's marine markets. So wherever you sail, you can be sure of fast access to our service, spare parts and know-how.

SELDÉN and FURLEX are registered trademarks of Seldén Mast AB.

[www.seldenmast.com](http://www.seldenmast.com)

