

# *E40i*

electric winch



# E40i - The easily placed electric winch

The coach roof is the normal place for a winch that operates halyards, reef lines, outhaul and control lines.

The E40i winch is built up around an electric motor which is totally integrated in the drum. Only three thin cables are protruding to lead through the coach roof or the deck, no large cutouts and no external motor or gearbox.

This makes for uncompromised headroom down below.

## No sweat

Hoisting your main will no longer be a struggle. Self-tailing function and 3-speed operation makes E40i ideal for any line where you need the combination of speed and fine-tuning.

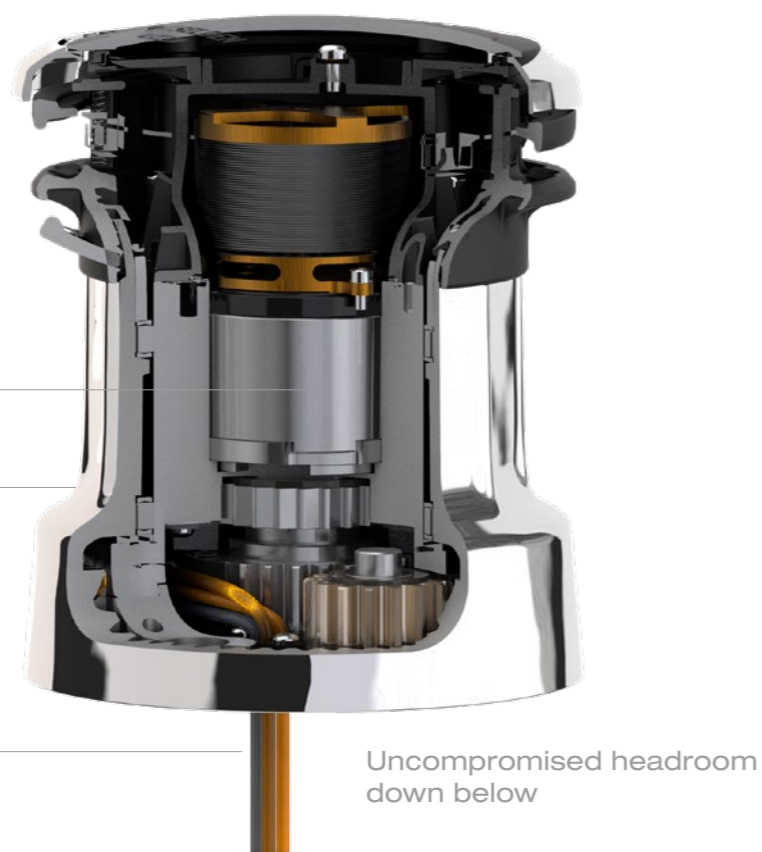

Electric motor, 42V

Stainless or Aluminium drum

Three 6 mm<sup>2</sup> cables

Uncompromised headroom down below



Scan and watch  
Synchronized Main  
Furling

E40i is powered up by Seldén's SEL-Bus system and a Power Supply Unit converting 12/24V to 42V which makes for an efficient and compact design. An interplay between E40i and Seldén's electric furling mast forms the ingenious **Synchronized Main Furling** system developed by Seldén. Press one button and E40i will tension the outhaul simultaneously as the mast motor unfurls the sail from the mast.



| Art. No.   | E40i           |
|------------|----------------|
| 471-540-10 | Stainless drum |
| 471-540-20 | Aluminium drum |



## TECHNICAL SPECIFICATION

|                       |                                  |
|-----------------------|----------------------------------|
| Base dia, ø mm        | 167                              |
| Drum dia, ø mm        | 128                              |
| Height, mm            | 198                              |
| Weight, kg            | Stainless: 9,1    Aluminium: 6,8 |
| Line entry height, mm | 60                               |
| Line entry angle      | 5-10°                            |

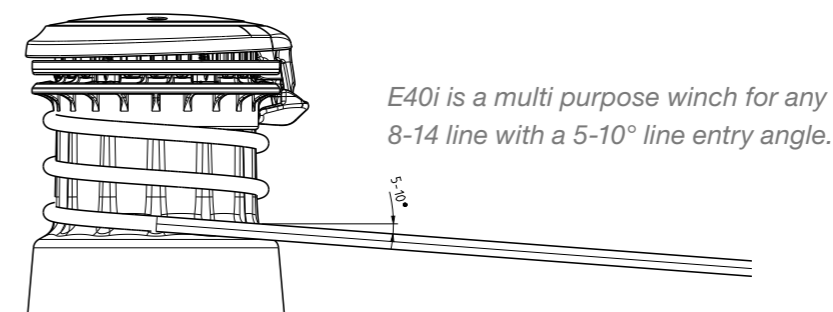

E40i is a multi purpose winch for any 8-14 line with a 5-10° line entry angle.

| Operation                   | 3-speed  |
|-----------------------------|--|
| Line speed, m/min           | Line speed 1 (m/min) 17<br>Line speed 2 (m/min) 11<br>Line speed 3 (m/min) 6,5 |
| Line size, ø mm             | 8-14   |
| Power consumption, W        | 1200   |
| Cable size, mm <sup>2</sup> | 6  |
| Voltage                     | 42   |

## Ordering E40i

Contact an authorized Seldén dealer for a quote including SEL-Bus and Power Supply Unit. Technical information and part numbers are available at [www.seldenmast.com/technical information](http://www.seldenmast.com/technical-information).

# DINGHIESKEELBOATSYACHTS

**Seldén Mast AB, Sweden**

Tel +46 (0)31 69 69 00  
e-mail [info@seldenmast.com](mailto:info@seldenmast.com)

**Seldén Mast Limited, UK**

Tel +44 (0)1329 50 40 00  
e-mail [info@seldenmast.co.uk](mailto:info@seldenmast.co.uk)

**Seldén Mast Inc., USA**

Tel +1 843-760-6278  
e-mail [info@seldenus.com](mailto:info@seldenus.com)

**Seldén Mast A/S, Denmark**

Tel +45 39 18 44 00  
e-mail [info@seldenmast.dk](mailto:info@seldenmast.dk)

**Seldén Mid Europe B.V.,  
Netherlands**

Tel +31 (0)111-698 120  
e-mail [info@seldenmast.nl](mailto:info@seldenmast.nl)

**Seldén Mast SAS, France**

Tel +33 (0)251 362 110  
e-mail [info@seldenmast.fr](mailto:info@seldenmast.fr)

**Seldén Mast Asia Ltd,  
Hong Kong**

Tel +852 3572 0613  
e-mail [info@seldenmast.com.hk](mailto:info@seldenmast.com.hk)

[www.seldenmast.com](http://www.seldenmast.com)

The Seldén Group is the world's leading manufacturer of mast and rigging systems in carbon and aluminium for dinghies, keelboats and yachts.

Our well known brands are Seldén and Furlex.

The worldwide success of Furlex has enabled us to build a network of over 750 authorised dealers covering the world's marine markets. So wherever you sail, you can be sure of fast access to our service, spare parts and know-how.

SELDÉN and FURLEX are registered trademarks of Seldén Mast AB.