

REPLACEMENT OF PRESSURE GAUGE ON HTI TENSIONER, 583-500-10

This document applies for tensioners:
HTI-W8/10 and HTI-W12/14
The repair kit includes parts for both sizes.

Included Part

- 1x Gauge
- 1x O-ring
- 2x Spring pin
- 1x Support collar:
 - 584-107 for HTI-W8/10
 - 584-108 for HTI-W12/14



Tools

- Hex wrench, 8 mm
- Pin Punch 2.5 mm
- Hammer



Releasing pressure before disassembly

1. Open the release valve and pull the rod out

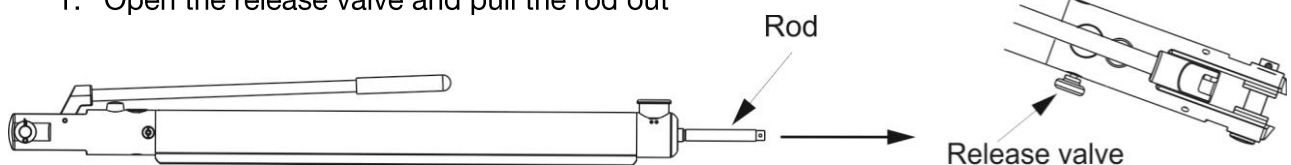

2. Place the oil plug as the highest point. Open it carefully with the 8mm hex wrench (to make sure there is no pressure inside)

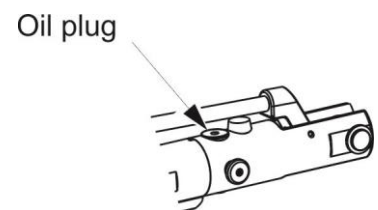

3. Close the oil plug again

Removal of old gauge

1. Punch out the spring pins that hold the old gauge, by using a pin punch (2.5 mm) and pull out the gauge.

 Some oil will pour out during this operation, make sure to do this in suitable location.

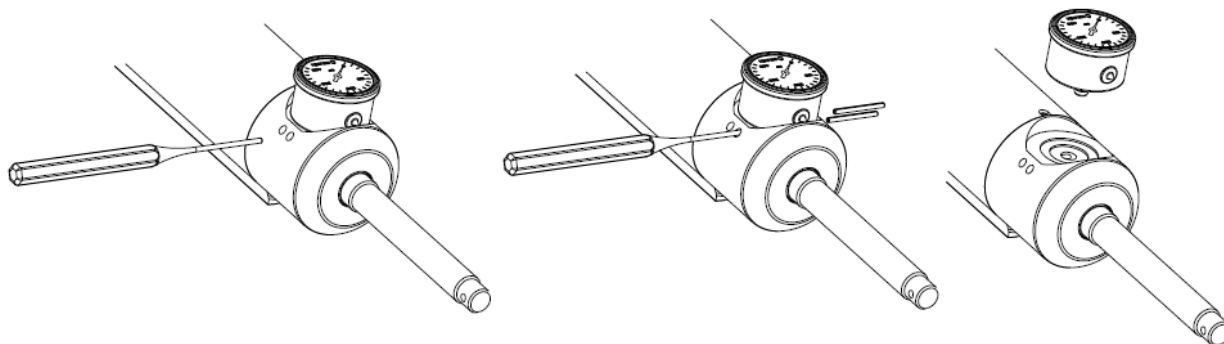

Fitting the new gauge

1. Prepare the new gauge, place the O-ring around the gauge and fit the support collar onto the gauge.

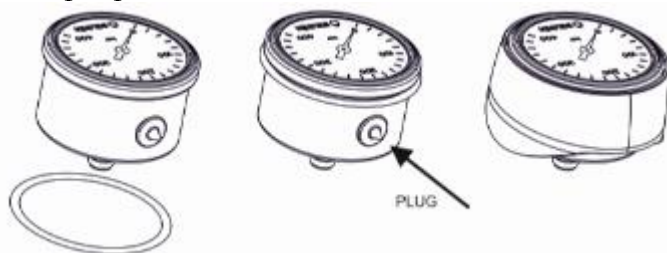

 Make sure that the rubber plug on the gauge stays in place and no oil leaks out.

2. Make sure that seat free from burrs or is damaged in anyway otherwise the sealing of the new gauge will not seal properly. Place the gauge in the seat on the tensioner, push it into place.

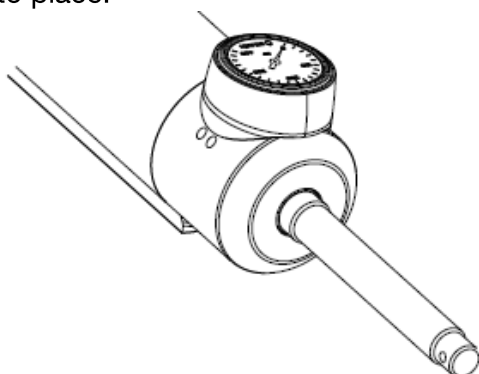

3. Rotate the gauge in place.

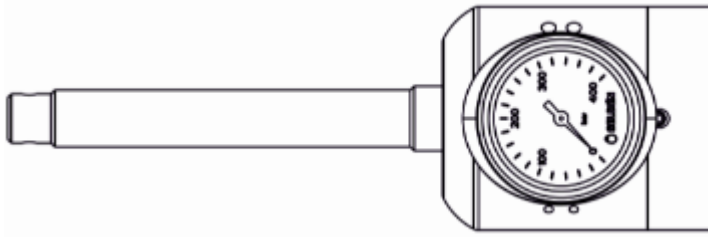

4. Place the new spring pins in the holes and punch them in, use pin punch, so that the pin comes completely into the HTI tensioner. Apply pressure on the top of the gauge to help the pins to slide in place.

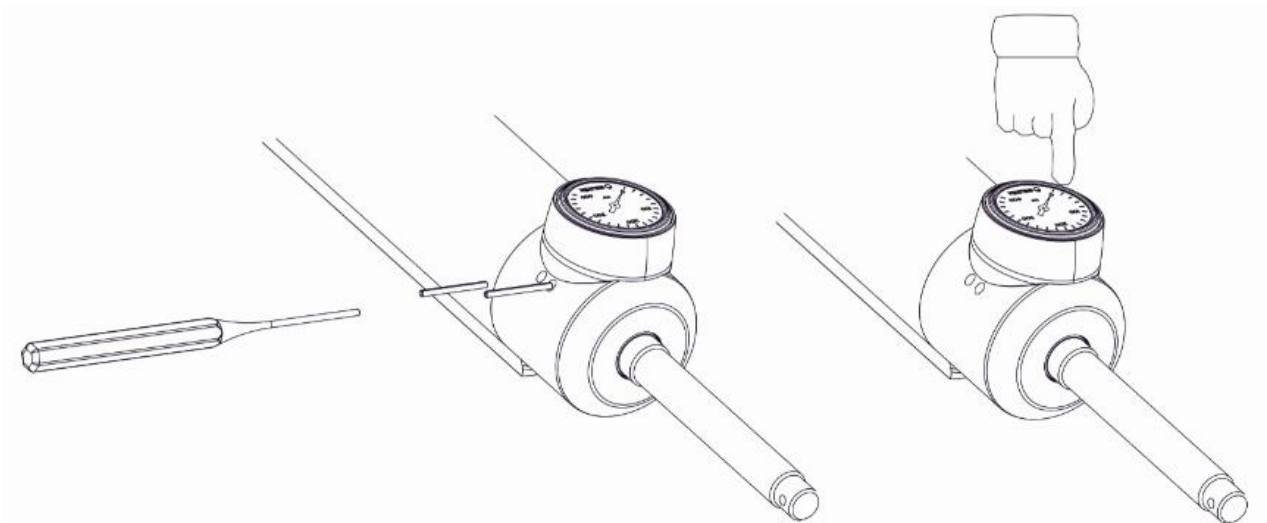

5. Clean and wipe of oil that has leaking out during repair. Oil may get caught under the support collar and only slowly creep out, so the cleaning might have to be repeated.

Removal of trapped air

1. Close the release valve
2. With tensioner in **vertical** position, operate the pump lever until the rod is contracted to its inward end position
3. Open the release valve
4. With tensioner in **vertical** position, operate the pump lever back and forth approximately 10 times slowly
5. With tensioner in **horizontal** position, pull the rod out. (Handle downwards)
6. Close the release valve
7. With tensioner in **vertical** position, operate the pump lever until the rod is contracted to its inward end position
8. Open the release valve
9. With tensioner in **vertical** position, operate the pump lever back and forth approximately 10 times slowly

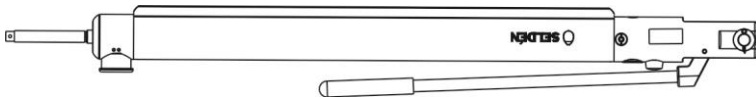

Pressure test

Before the tensioner is refitted on the boat is recommended to do a pressure test.

1. Close the release valve.
2. Operate the pump lever back and forth until the pressure is approximately 150 bar and live it for approximately 12 hours with the tensioner in a vertical position.
3. Check for any oil leaks in the area around the gauge. If oil comes out under the support collar, clean it off and wait for another 12 hours, oil from the repair might have get caught under the support collar and only slowly creep out